

UP

**Diaphragm**  
Property of Ultrapharma BV

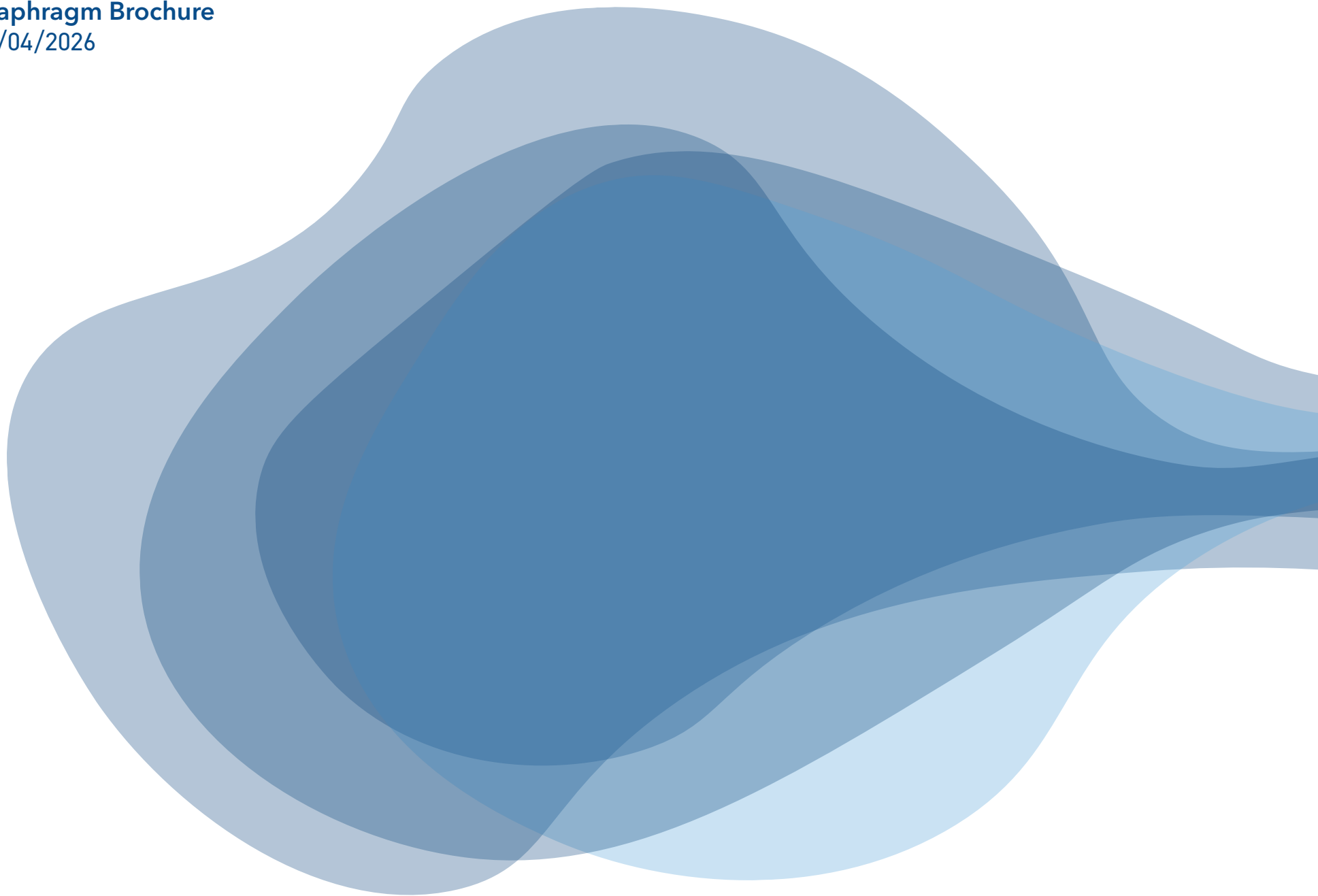

## Table of Contents

1. Introducing OEM diaphragms .....	4
2. Compounds.....	4
3. Nominal dimensions in mm (in.).....	8
4. Partnumbers .....	8
5. Specifications .....	10
6. Assembly specifications.....	10

## 1. Introducing OEM diaphragms

Diaphragms are maintenance repair and operation (MRO) parts that need to be replaced in the same frequency as e.g. Sanitary gaskets. The radial-style diaphragms that we are manufacturing now are made with the same focus on quality as our complete gasket range. The beauty of our offering is that some of the compounds we use for our diaphragms have already been validated through the gasket products we have in de field for over a decade. Our in house testing facility is able to duplicate SIP cycling and endurance testing to proof quality of the highest standard.

## 2. Compounds

Today the need for traceability for contact material in the pharmaceutical industry is eminent. We need to know what we are getting and we need to know if the supply chain is consistent time after time.

One way to secure consistency is to introduce compound numbers. If compound numbers are linked to product numbers one creates the condition that the manufacturer cannot change from one compound to another. Once a gasket is validated and known by its compound and part number there is no possibility to change things. This is what we are seeking for in today's industry.

Most pharmaceutical companies require a written notification for any change in the manufacturing process including compound changes. The impact of compound changes can be severe, is expensive and time consuming, in which no one is eager to get involved with.

This is why Ultrapharma is introducing designated compound numbers for all products.

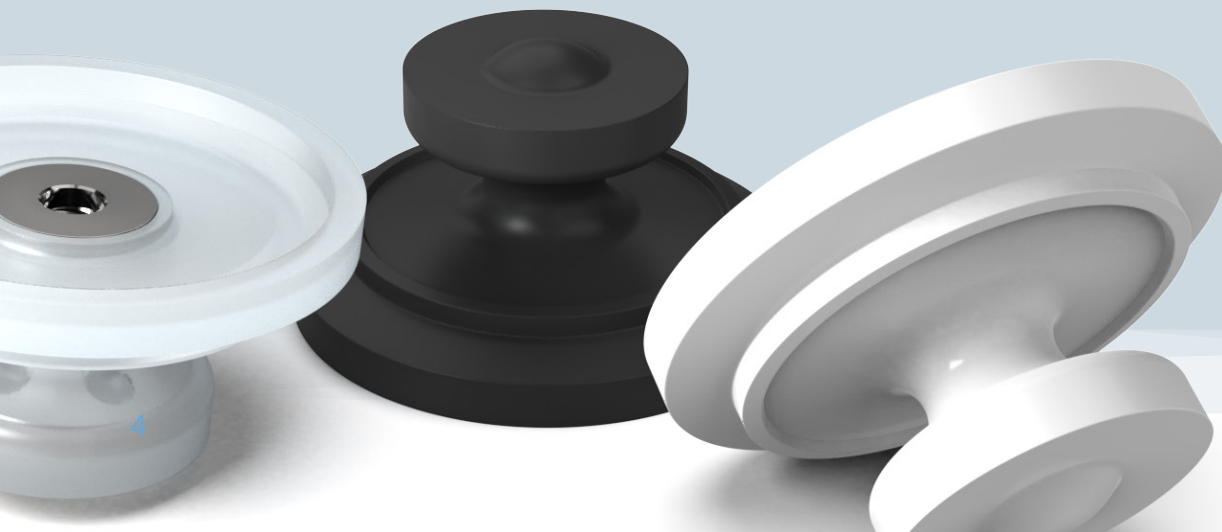

Compound Data Sheets will tell exactly what the compound is all about including all its credentials such as FDA-CFR listing, USP Class VI and other relevant test criteria. All clients of Ultrapharma have access to these Compound Data Sheets (CMD), they can advise pharmaceutical end-users of the existence and determine which compound to use for their applications. The compound number that has been chosen can be referred to at any point in time when ordering new gaskets.

The Certificates of Conformance that we generate for all products are now made automatically within our ERP system. The compound data is stored in our SAP system, all information about lot numbers is centralized. In the final stage all information is gathered and printed on the Certificate of Conformance. All is based on the one specific compound fully traceable.



**Document number**  
CDS-7001-1004

---

**Compound Data Sheet**

<b>Compound number</b>	CMD-1004
<b>Material</b>	Peroxide cured EPDM (ethylene propylene diene monomer)
<b>Colour</b>	Black
<b>Odour</b>	None
<b>Temperature range</b>	-40°C / +150°C (short 170°C)
<b>Storage stability</b>	10 Years

Property (Norm)	Requirements	Results
Hardness (Shore A) (ASTM D2240)	70 ± 5	74
Tensile strength (ASTM D412-06)	≥ 7.0 MPa	10.70 MPa
Elongation (ASTM D412-06)	≥ 150 %	187 %
Compression set (220/4/150°C, ASTM D395/B)	20 %	8.5 %
Specific gravity		1.156 g/cm <sup>3</sup>

**Meets**

<b>FDA</b>	CFR 177.2600
<b>USP 42</b>	<87> Cytotoxicity
<b>USP 30</b>	<88> Class VI - 121°C
<b>USP 28</b>	<381> Physicochemical
<b>ADIF</b>	Animal Derived Ingredients Free (BSE/TSE free)
<b>EC</b>	EC1935/2004 for water and acid only

**General Advice**

<b>SIP</b>	Good (short exposure)
<b>CP</b>	Good
<b>Oil &amp; Fat</b>	Poor
<b>WFI</b>	Good
<b>Sterilization</b>	Excellent
<b>Steam Sterilization</b>	Good

This information is accurate to the best of our knowledge. We advise the users of our products to perform their own testing for chemical compatibility and suitability for particular applications.

Ultrapharma BV  
 De Droogmakerij 12 1851 LX Heiloo The Netherlands  
 www.ultrapharma.com | +31 856 200 900 | info@ultrapharma.com

# Diaphragm Brochure

23/04/2026

Compound number	Material	FDA CFR 177.2600	USP Cytotoxicity <87>	USP Class VI-121° <88>	USP Physicochemical testing <381>	EP 3.1.9	Conform ADIF
CMD-1066-SS316	EPDM	✓	✓	✓	✓		✓
CMD-1089-SS316	FKM	✓	✓				✓
CMD-1065-SS316	White Silicone	✓	✓	✓	✓		✓
CMD-1012-SS316	Translucent Silicone	✓	✓	✓	✓	✓	✓

## EPDM

EPDM, Ethylene Propylene Diene Monomer, is an “M” class synthetic rubber elastomer. The M class comprises elastomers having a saturated chain of the polyethylene type (the M deriving from the more correct term polymethylene)

EPDM is one of the most popular and versatile polymer in sealing applications. It remains flexible in a wide range of temperatures, this is why it has excellent sealing capacities. Chemically, EPDM has good resistance to animal oils, vegetable oils, ozone, strong chemicals, and oxidizing chemicals. Do not use EPDM gaskets for mineral oils, solvents, or aromatic hydrocarbons.

## Platinum Silicone (White & Translucent)

Silicone is widely used in pharmaceutical applications for two major reasons. First, and foremost, is safety. Silicone does not contain plasticizers or other additives that could leach into a drug product and cause toxicological issues. Second, silicone is highly flexible and tear-resistant, making it a good choice for sealing fluids in downstream processes.

In order to make silicone gaskets there are two cure system options with silicones, however, that produces materials with different characteristics, whose impact should be considered before selection. Silicone materials may be cured using free radical (peroxide) or addition (platinum) cure mechanisms. Platinum-cured and peroxide-cured silicone gaskets can both be made to USP Class VI and other industry specifications, but a platinum-cured gasket has a higher purity and lower leachability than peroxide-cured silicone.

### Important notice about Silicone

Silicone is porous and will allow water and other molecules to permeate through. This can be observed when small amounts of water leave the bleeding hole in the actuator. When the actuator is hot the water will be evaporated and won't be observed. Silicone because of its porosity will absorb traces of active media. This should be considered when selecting diaphragm material.

### Traceability

All diaphragms are laser etched with the designated size number, the unique lot number and D.O.M. securing full traceability even when they leave their packaging. After use the data can still be retrieved from the diaphragm. Each shipment that we make comes always with a certificate of conformance (CoC).

### ISO7 Cleanroom packed

As an option, all diaphragms can be ordered with Cleanroom packaging securing the best possible quality entering your cleanroom operation.



# Diaphragm Brochure

23/04/2026

## 3. Nominal dimensions in mm (in.)

Diaphragm	Size	ØA	B	ØC	Int. Size
DN12	050	34.0 (1.339)	16.0 (0.630)	18.0 (0.709)	1/2"
DN18	075	46.5 (1.831)	22.5 (0.984)	25.0 (0.984)	3/4"
DN25	100	62.0 (2.441)	28.0 (1.102)	34.0 (1.339)	1"
DN38	150	75.0 (2.953)	41.0 (1.614)	48.0 (1.890)	1.5"
DN51	200	97.0 (3.819)	51.0 (2.008)	64.0 (2.520)	2"

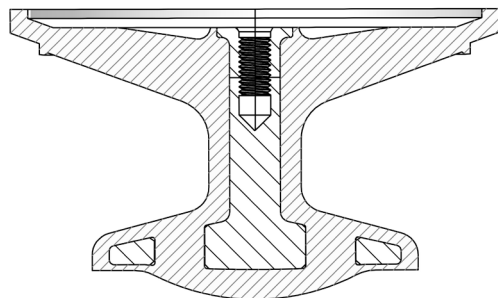
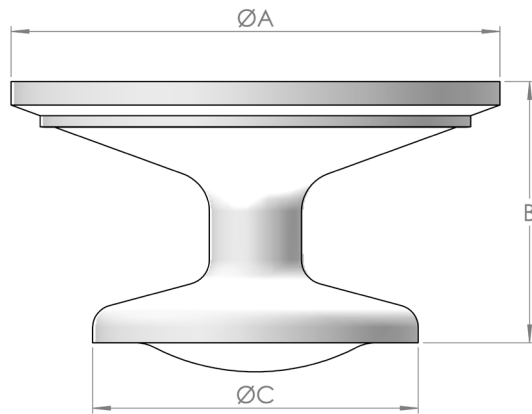

## 4. Partnumbers

### DN12 (1/2") radial-style diaphragm

Compound	Article Number	Compound Number	Artc. nr. Cleanroom Packed
EPDM	UP-RD-MPE-DN12	CMD-1066-316SS	UP-RD-MPE-DN12-CRP
White Silicone	UP-RD-RXPXW-DN12	CMD-1065-316SS	UP-RD-RXPXW-DN12-CRP
Translucent Silicone	UP-RD-RXPXC-DN12	CMD-1012-316SS	UP-RD-RXPXC-DN12-CRP
FKM	UP-RD-MPSFY-DN12	CMD-1089-316SS	UP-RD-MPSFY-DN12-CRP

### DN18 (3/4") radial-style diaphragm

Compound	Article Number	Compound Number	Artc. nr. Cleanroom Packed
EPDM	UP-RD-MPE-DN18	CMD-1066-316SS	UP-RD-MPE-DN18-CRP
White Silicone	UP-RD-RXPXW-DN18	CMD-1065-316SS	UP-RD-RXPXW-DN18-CRP
Translucent Silicone	UP-RD-RXPXC-DN18	CMD-1012-316SS	UP-RD-RXPXC-DN18-CRP
FKM	UP-RD-MPSFY-DN18	CMD-1089-316SS	UP-RD-MPSFY-DN18-CRP

#### DN25 (1") radial diaphragm

Compound	Article Number	Compound Number	Artc. nr. Cleanroom Packed
EPDM	UP-RD-MPE-DN25	CMD-1066-316SS	UP-RD-MPE-DN25-CRP
FKM	UP-RD-MPSFY-DN25	CMD-1089-316SS	UP-RD-MPSFY-DN25-CRP
White Silicone	UP-RD-RXPXW-DN25	CMD-1065-316SS	UP-RD-RXPXW-DN25-CRP
Translucent Silicone	UP-RD-RXPXC-DN25	CMD-1012-316SS	UP-RD-RXPXC-DN25-CRP

#### DN38 (1-1/2") radial diaphragm

Compound	Article Number	Compound Number	Artc. nr. Cleanroom Packed
EPDM	UP-RD-MPE-DN38	CMD-1066-316SS	UP-RD-MPE-DN38-CRP
FKM	UP-RD-MPSFY-DN38	CMD-1089-316SS	UP-RD-MPSFY-DN38-CRP
White Silicone	UP-RD-RXPXW-DN38	CMD-1065-316SS	UP-RD-RXPXW-DN38-CRP
Translucent Silicone	UP-RD-RXPXC-DN38	CMD-1012-316SS	UP-RD-RXPXC-DN38-CRP

#### DN51 (2") radial diaphragm

Compound	Article Number	Compound Number	Artc. nr. Cleanroom Packed
EPDM	UP-RD-MPE-DN51	CMD-1066-316SS	UP-RD-MPE-DN51-CRP
FKM	UP-RD-MPSFY-DN51	CMD-1089-316SS	UP-RD-MPSFY-DN51-CRP
White Silicone	UP-RD-RXPXW-DN51	CMD-1065-316SS	UP-RD-RXPXW-DN51-CRP
Translucent Silicone	UP-RD-RXPXC-DN51	CMD-1012-316SS	UP-RD-RXPXC-DN51-CRP



# Diaphragm Brochure

23/04/2026

## 5. Specifications

Material	Min. Temp	Max. Temp **	Head pressure against spring load *	Vacuum	SIP Max.
EPDM	-15 °C	175 °C	6 Bar (85PSI)	-1 Bar (-14.5 PSI)	135 °C
FKM	-30 °C	200 °C	6 Bar (85PSI)	-1 Bar (-14.5 PSI)	135 °C
WHITE PT. SILICONE	-40 °C	200 °C	6 Bar (85PSI)	-1 Bar (-14.5 PSI)	135 °C
TRANSLUCENT PT. SILICONE	-40 °C	200 °C	6 Bar (85PSI)	-1 Bar (-14.5 PSI)	130 °C

\* Actuator is N/C spring closed

\*\* Short exposure

## 6. Assembly specifications

It is important to assemble the diaphragm in the correct order and with the correct torque momentum. Under torquing will inevitably lead to breaches over the shoulder sealing ridge causing potential contamination. Recommended torque on all diaphragm's is 4.0Nm.



 **Ultrapharma**<sup>bv</sup>

De Droogmakerij 12

1851 LX Heiloo

The Netherlands

+31 856 200 900

[info@ultrapharma.com](mailto:info@ultrapharma.com)

